

Centrifugal horizontal pump

OR

Carters and safety devices compliant with EN60240-1 CE

Transmission
Direct drive (TDM models)
Belts and pulleys (IN & TD models)

Pump body lined with anti-abrasive, high-thickness natural rubber, removable or vulcanised.



Common spare parts
for our whole range of centrifugal pumps

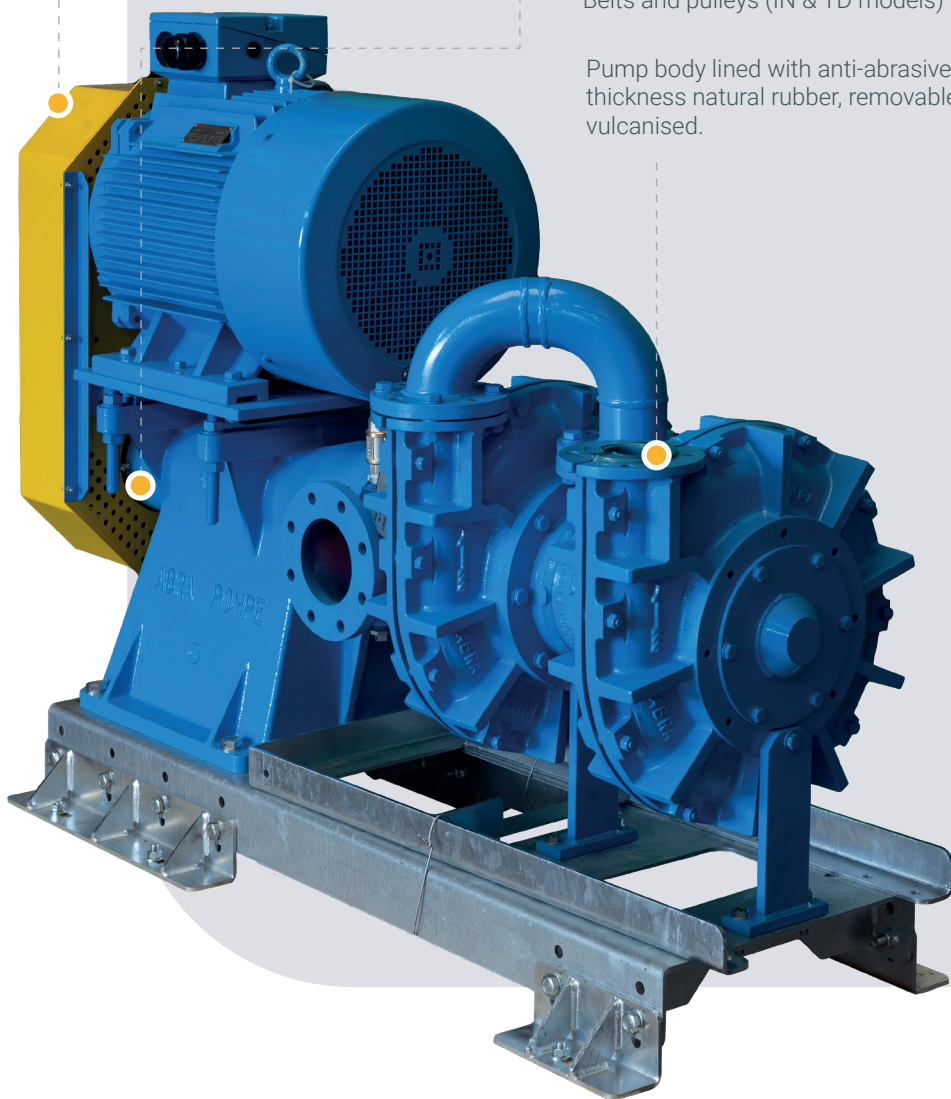

Double stage pump

For filterpress feeding and pressurization up to 16 bar (H₂O)

Open blade impeller, rubber-lined or chromium-hardened-steel made



Single stage pump

Seals cooling system in close loop
Containerized solution



Technical specifications

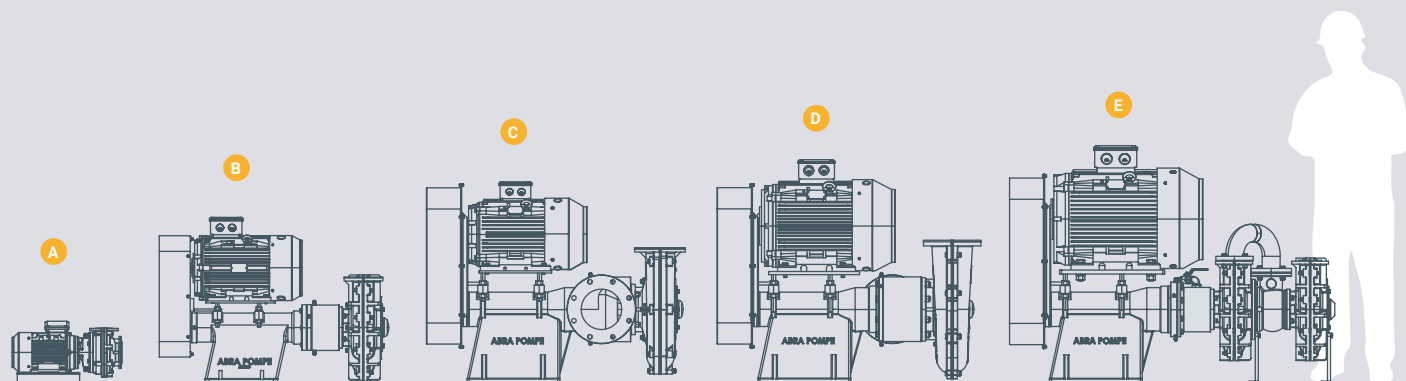

Model	Flow	Head	Power	Txp. Weight *
-	m ³ /h	mH ₂ O	kW	kg
30 OR - INX	5 - 60	25 - 5	1,5 - 7,5	50 - 110
30 OR - TDX	5 - 60	25 - 5	1,5 - 7,5	50 - 110
A 30 OR - TDM	5 - 60	25 - 5	1,5 - 7,5	50 - 110
40 OR - INX	10 - 80	35 - 10	2,2 - 15	100 - 130
40 OR - TDX	10 - 80	35 - 10	2,2 - 15	100 - 130
40 OR - TDM	10 - 80	35 - 10	2,2 - 15	100 - 130
50 OR - INX	15 - 100	40 - 15	4 - 15	200 - 300
50 OR - TDX	15 - 100	40 - 15	4 - 15	200 - 300
50 OR - TDM	15 - 100	40 - 15	4 - 15	200 - 300
60 OR - TD	20 - 120	60 - 20	7,5 - 30	340 - 490
60 OR - TDM	20 - 120	60 - 20	7,5 - 30	340 - 490
B 61 OR - IN	20 - 120	60 - 20	7,5 - 22	340 - 490
61L OR - IN	20 - 120	60 - 20	18,5 - 30	340 - 490
E 61TW OR - IN	20 - 120	160 - 40	30 - 55	800 - 1000
62B OR - IN	20 - 120	60 - 20	18,5 - 30	340 - 490
80 OR - IN	30 - 180	40 - 20	7,5 - 30	400 - 600
80 OR - TD	30 - 180	40 - 20	7,5 - 30	400 - 600
C 100 OR - INX	40 - 240	45 - 20	11 - 55	600 - 800
100 OR - TDX	40 - 240	45 - 20	11 - 55	600 - 800
D 150 OR - INX	80 - 450	45 - 20	22 - 75	700 - 1000
150 OR - TDX	80 - 450	45 - 20	22 - 75	700 - 1000
150TW OR-IN	80 - 450	160 - 40	55 - 90	1500 - 2000

* indicative average weight, depending on configuration

The reported data are valid for general information purpose and can not be guaranteed for executive design. For detailed data and specific needs refer to sales@tecnoida.it